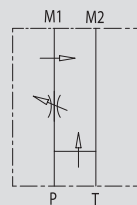
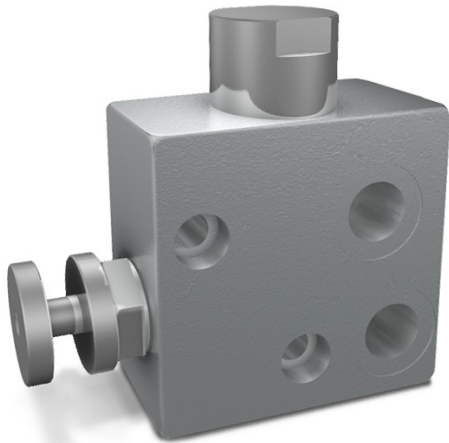

REGOLATORE DI FLUSSO PRIORITARIO FLANGIABILE PER MOTORI DANFOSS OMS

TIPO / TYPE

RFP3 OMSSCHEMA IDRAULICO
HYDRAULIC DIAGRAM

FLOW CONTROL VALVE EXCESS TO TANK FLANGEABLE ON DANFOSS MOTORS OMS

IMPIEGO:

Valvola che consente di mantenere costante la portata in P ad un valore stabilito, indipendentemente dalla pressione richiesta e dalla portata in entrata alla valvola. La portata in eccesso viene mandata direttamente sulla linea di ritorno (T).

MATERIALI E CARATTERISTICHE:

Corpo: acciaio zincato
Componenti interni: acciaio temprato termicamente e rettificato
Guarnizioni: BUNA N standard
Tenuta: per accoppiamento. Trafilamento minimo (poche gocce al minuto)

MONTAGGIO:

Flangiare M1 e M2 al motore, collegare le bocche P e T all'alimentazione.

USE AND OPERATION:

This valve enables to keep "P" flow constant to a certain setting, independently of the required pressure or the inlet flow of the valve. Exceeded flow is drained directly in T (tank).

MATERIALS AND FEATURES:

Body: zinc-plated steel
Internal parts: hardened and ground steel
Seal: BUNA N standard
Tightness: by diameter combination. Minor leakage (few drops per minute)

APPLICATIONS:

Connect M1 and M2 to the motor and P and T to the pressure.



CODICE CODE	SIGLA TYPE	PORTATA MAX ENTRANTE MAX INLET FLOW Lt. / min	PORTATA MAX REGOLATA MAX ADJUSTED FLOW Lt. / min	PRESSIONE MAX MAX PRESSURE Bar
V1122	RFP3 1/2" OMS	60	50	350

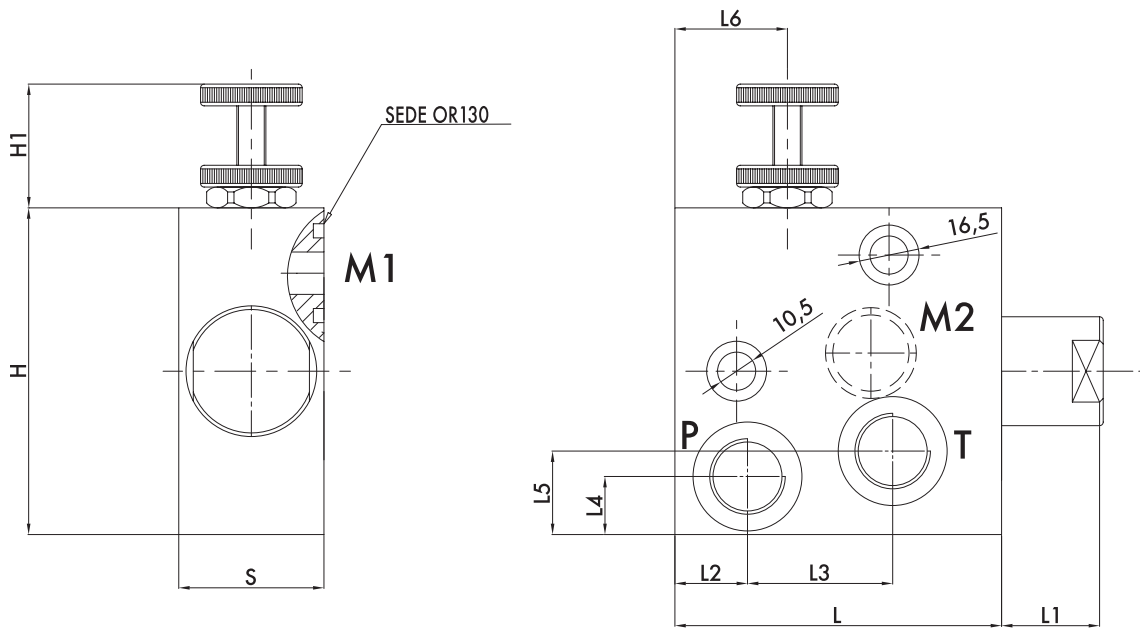

CODICE CODE	SIGLA TYPE	P. T GAS	L mm	L1 mm	L2 mm	L3 mm	L4 mm	L5 mm	L6 mm	H mm	H1 mm	S mm	PESO WEIGHT kg
V1122	RFP3 1/2" OMS	G1/2"	90	26	20	40	16	23	31	90	35	40	2,410